

# Keysight Configurable Test Set Upgrade Kit

To Upgrade PNA N5227A Option 200 to Option 201  
Upgrade Kit Order Number: N5227AU- 201  
Keysight Kit Number: N5227-60101



NOTICE: This document contains references to Agilent Technologies. Agilent's former Test and Measurement business has become Keysight Technologies. For more information, go to [www.keysight.com](http://www.keysight.com).



---

## WARRANTY STATEMENT

THE MATERIAL CONTAINED IN THIS DOCUMENT IS PROVIDED "AS IS," AND IS SUBJECT TO BEING CHANGED, WITHOUT NOTICE, IN FUTURE EDITIONS. FURTHER, TO THE MAXIMUM EXTENT PERMITTED BY APPLICABLE LAW, KEYSIGHT DISCLAIMS ALL WARRANTIES, EITHER EXPRESS OR IMPLIED WITH REGARD TO THIS MANUAL AND ANY INFORMATION CONTAINED HEREIN, INCLUDING BUT NOT LIMITED TO THE IMPLIED WARRANTIES OF MERCHANTABILITY AND FITNESS FOR A PARTICULAR PURPOSE. KEYSIGHT SHALL NOT BE LIABLE FOR ERRORS OR FOR INCIDENTAL OR CONSEQUENTIAL DAMAGES IN CONNECTION WITH THE FURNISHING, USE, OR PERFORMANCE OF THIS DOCUMENT OR ANY INFORMATION CONTAINED HEREIN. SHOULD KEYSIGHT AND THE USER HAVE A SEPARATE WRITTEN AGREEMENT WITH WARRANTY TERMS COVERING THE MATERIAL IN THIS DOCUMENT THAT CONFLICT WITH THESE TERMS, THE WARRANTY TERMS IN THE SEPARATE AGREEMENT WILL CONTROL.

---

## DFARS/Restricted Rights Notice

If software is for use in the performance of a U.S. Government prime contract or subcontract, Software is delivered and licensed as "Commercial computer software" as defined in DFAR 252.227-7014 (June 1995), or as a "commercial item" as defined in FAR 2.101(a) or as "Restricted computer software" as defined in FAR 52.227-19 (June 1987) or any equivalent agency regulation or contract clause. Use, duplication or disclosure of Software is subject to Keysight Technologies' standard commercial license terms, and non-DOD Departments and Agencies of the U.S. Government will receive no greater than Restricted Rights as defined in FAR 52.227-19(c)(1-2) (June 1987). U.S. Government users will receive no greater than Limited Rights as defined in FAR 52.227-14 (June 1987) or DFAR 252.227-7015 (b)(2) (November 1995), as applicable in any technical data.

---

## Safety Notes

The following safety notes are used throughout this document. Familiarize yourself with each of these notes and its meaning before performing any of the procedures in this document.

---

**WARNING**      **Warning denotes a hazard. It calls attention to a procedure which, if not correctly performed or adhered to, could result in injury or loss of life. Do not proceed beyond a warning note until the indicated conditions are fully understood and met.**

---

---

**CAUTION**      Caution denotes a hazard. It calls attention to a procedure that, if not correctly performed or adhered to, could result in damage to or destruction of the instrument. Do not proceed beyond a caution sign until the indicated conditions are fully understood and met.

---

---

## Description of the Upgrade

This upgrade converts your Option 200 2-port analyzer (N5227A Option 200) to an Option 201 analyzer by adding:

- configurable test set (front panel loops)
- a reference mixer switch

After installation of this upgrade, your analyzer will be an N5227A Option 201.

---

## Getting Assistance from Keysight

Installing this upgrade kit requires special skills and experience. If you think you may not be qualified to do the work, or need advice, contact Keysight.

### Contacting Keysight

Assistance with test and measurements needs and information on finding a local Keysight office are available on the Web at:

<http://www.keysight.com/find/assist>

If you do not have access to the Internet, please contact your Keysight field engineer.

---

**NOTE** In any correspondence or telephone conversation, refer to the Keysight product by its model number and full serial number. With this information, the Keysight representative can determine whether your product is still within its warranty period.

---

---

## Getting Prepared

---

**CAUTION** The PNA contains extremely sensitive components that can be ruined if mishandled. Follow instructions carefully when making cable connections, especially wire harness connections.

The person performing the work accepts responsibility for the full cost of the repair or replacement of damaged components.

---

To successfully install this upgrade kit, you will need the following:

- A license key - refer to “[License Key Redemption](#)” below.
- A PDF copy or a paper copy of the PNA Service Guide - refer to “[Downloading the Online PNA Service Guide](#)” below.
- An ESD-safe work area - refer to “[Protecting Your Workspace from Electrostatic Discharge](#)” below.
- Correct tools - refer to “[Tools Required for the Installation](#)” on page 6.
- Enough time - refer to “[About Installing the Upgrade](#)” on page 6.
- Test equipment for the post-upgrade adjustments and full instrument calibration. To view the equipment list, click the Chapter 3 bookmark “[Tests and Adjustments](#)” in the PDF Service Guide<sup>1</sup>.

## License Key Redemption

---

**NOTE** The enclosed Option Entitlement Certificate is a receipt, verifying that you have purchased a licensed option for the PNA of your choice. You must now use a Keysight Web page to request a license key for the instrument that will receive the option.

---

To enable the option product, you must request a license key from: <http://www.keysight.com/find/softwarelicense>. To complete the request, you will need to gather the following information:

- From the certificate
  - Order number
  - Certificate number
- From your instrument
  - Model number
  - Serial number
  - Host ID

---

1. See “[Downloading the Online PNA Service Guide](#)” on page 5.

The instrument information is available on the network analyzer – on the analyzer’s **Help** menu, click **About Network Analyzer**.

If you provide an email address, Keysight will promptly email your license key. Otherwise, you will receive your license key via postal mail.

## Downloading the Online PNA Service Guide

To view the online Service Guide for your PNA model number, use the following steps:

1. Go to [www.keysight.com](http://www.keysight.com).
2. In the Search box, enter the model number of the analyzer (Ex: N5227A) and click **Search**.
3. Click Technical Support > Manuals.
4. Click Service Manual.
5. Click the service guide title to download the PDF file.
6. When the PDF of the Service Guide is displayed, scroll through the Contents section bookmarks to locate the information needed.

## Protecting Your Workspace from Electrostatic Discharge

For information, click on the Chapter 1 bookmark, “Electrostatic Discharge Protection” in the PDF Service Guide<sup>1</sup>.

### ESD Equipment Required for the Installation

Description	Keysight Part Number
ESD grounding wrist strap	9300-1367
5-ft grounding cord for wrist strap	9300-0980
2 x 4 ft conductive table mat and 15-ft grounding wire	9300-0797
ESD heel strap (for use with conductive floors)	9300-1308

1. See “[Downloading the Online PNA Service Guide](#)” on page 5.

## Tools Required for the Installation

Description	Qty	Part Number
T-10 TORX driver - set to 9 in-lbs (1.02 N.m)	1	N/A
T-20 TORX driver - set to 21 in-lbs (2.38 N.m)	1	N/A
5/16-in (8 mm) nutsetter or open end torque wrench- set to 10 in-lbs (1.13 N.m)	1	N/A
9 mm nutsetter or open end torque wrench - set to 21 in-lbs (2.38 N.m)	1	N/A
1/4-in (6 mm) open end wrench	1	N/A
1-in (25.4 mm) torque wrench - set to 72 in-lbs (8.15 N.m)	1	N/A

**CAUTION** Use a 5/16-in torque wrench set to 10 in-lbs on all cable connections except the front and rear panel bulkhead connectors. On these, use a 9 mm nutsetter or open end torque wrench set to 21 in-lb.

## About Installing the Upgrade

Products affected . . . . .	N5227A Option 200
Installation to be performed by . . . . .	Keysight service center or personnel qualified by Keysight
Estimated installation time . . . . .	3 hours
Estimated adjustment time . . . . .	0.5 hours
Estimated full instrument calibration time . . . . .	4.5 hours



## Items Included in the Upgrade Kit<sup>1</sup>

Check the contents of your kit against the following list. If any part is missing or damaged, contact Keysight Technologies. Refer to [“Contacting Keysight” on page 3](#).

**Table 1 Contents of Upgrade Kit N5227-60101**

Ref Desig.	Description	Qty	Part Number
--	Installation note (this document)	1	N5227-90101
A37	Reference mixer switch	1	5087-7759
--	Bracket for A37 reference mixer switch	1	N5245-00024
--	Wire harness cable for A37 reference mixer switch	1	8121-0966
--	Bulkhead connector, 1.85 mm, f-f, 50-ohm	12	5065-4673
--	Hex nut (for bulkhead connectors)	12	1250-3516
-	Washer for bulkhead connectors, front panel	12	1250-3310
--	Test set front plate (subpanel) (For 2-port models with front-panel jumpers.)	1	N5247-00008
--	Front panel overlay, 2-port (Option 201)	1	N5227-80015 Was: N5227-80009
--	Cable tie	7	1400-0249
--	Cable clamp	5	1400-1334
--	Cable guard	2	N5242-00029
--	Machine screw, M3.0 x 8, pan head (to attach reference mixer switch to bracket; to attach reference mixer switch assy to wall of test set deck)	5	0515-0372
W12	RF cable, A60 port 1 70 GHz doubler to W11	1	N5247-20059
W27	RF cable, A60 port 1 70 GHz doubler to A29 port 1 receiver coupler	1	N5247-20074
W30	RF cable, A63 port 2 70 GHz doubler to A32 port 2 receiver coupler	1	N5247-20052
W31	RF cable, A29 port 1 receiver coupler to front-panel port 1 SOURCE OUT	1	N5247-20037
W32	RF cable, front-panel port 1 CPLR THRU to A33 port 1 coupler	1	N5247-20049
W33	RF cable, A29 port 1 receiver coupler to A37 reference mixer switch	1	N5247-20056
W34	RF cable, A33 port 1 coupler to front-panel port 1 CPLR ARM	1	N5247-20039
W43	RF cable, A32 port 2 receiver coupler to front-panel port 2 SOURCE OUT	1	N5247-20036
W44	RF cable, front-panel port 2 CPLR THRU to A36 port 2 coupler	1	N5247-20050
W45	RF cable, A32 port 2 receiver coupler to front-panel REF 2 SOURCE OUT	1	N5247-20057
W46	RF cable, A36 port 2 coupler to front-panel port 2 CPLR ARM	1	N5247-20041
W47	RF cable, front-panel port 1 RCVR A IN to A27 mixer brick (A)	1	N5247-20053
W50	RF cable, front-panel port 2 RCVR B IN to A27 mixer brick (B)	1	N5247-20054
W51	RF cable, front-panel REF 1 SOURCE OUT to A37 reference mixer switch	1	N5247-20011
W52	RF cable, front-panel REF 1 RCVR R1 IN to A37 reference mixer switch	1	N5247-20012
W53	RF cable, A37 reference mixer switch to A27 mixer brick (R1)	1	N5247-20048
W56	RF cable, front-panel REF 2 RCVR R2 IN to A27 mixer brick (R2)	1	N5247-20055

1. In addition to the upgrade kit, the shipment includes an Option Entitlement Certificate. Refer to [“License Key Redemption” on page 4](#) for important information about this certificate.

**Table 1**      **Contents of Upgrade Kit N5227-60101**

<b>Ref Desig.</b>	<b>Description</b>	<b>Qty</b>	<b>Part Number</b>
W60	Front-panel jumper	6	N5247-20107

---

**NOTE**      Extra quantities of items such as protective plastic caps, screws, cable ties, and cable clamps may be included in this upgrade kit. It is normal for some of these items to remain unused after the upgrade is completed.

---

---

## Installation Procedure for the Upgrade

The network analyzer must be in proper working condition prior to installing this option. Any necessary repairs must be made before proceeding with this installation.

---

**WARNING**      **This installation requires the removal of the analyzer's protective outer covers. The analyzer must be powered down and disconnected from the mains supply before performing this procedure.**

---

### Overview of the Installation Procedure

- Step 1. Obtain a Keyword and Verify the Information.
- Step 2. Remove the Outer Cover.
- Step 3. Remove the Front Panel Assembly.
- Step 4. Remove Some Bottom-Side (Test Set) Cables.
- Step 5. Remove Port 1 and Port 2 Coupler Assemblies from Brackets Underneath.
- Step 6. Remove Brackets From Test Set Deck.
- Step 7. Reinstall the Port 1 and Port 2 Coupler Assemblies to Test Set Deck.
- Step 8. Assemble the Reference Mixer Switch.
- Step 9. Install the Reference Mixer Switch.
- Step 10. Remove the Test Set Front Plate Assembly From the Test Set Deck.
- Step 11. Move the LED Boards and Couplers to the New Test Set Front Plate.
- Step 12. Install Bulkhead Connectors on the Test Set Front Plate Assembly.
- Step 13. Install New Test Set Front Plate Assembly to Test Set Deck.
- Step 14. Install Some Bottom-Side (Test Set) Cables.
- Step 15. Remove the Old Lower Front Panel Overlay.
- Step 16. Reinstall Front Panel Assembly.
- Step 17. Install the New Lower Front Panel Overlay.
- Step 18. Install Front Panel Jumpers.
- Step 19. Position the Cables and Wires to Prevent Pinching.
- Step 20. Reinstall the Outer Cover.
- Step 21. Enable Option 201.
- Step 22. Perform Post-Upgrade Adjustments and Calibration.
- Step 23. Prepare the PNA for the User.

## **Step 1. Obtain a Keyword and Verify the Information**

Follow the instructions on the Option Entitlement Certificate supplied to obtain a license key for installation of this upgrade. Refer to [“License Key Redemption” on page 4](#).

Verify that the model number, serial number, and option number information on the license key match those of the instrument on which this upgrade will be installed.

If the model number, serial number, or option number do not match those on your license key, you will not be able to install the option. If this is the case, contact Keysight for assistance before beginning the installation of this upgrade. Refer to [“Contacting Keysight” on page 3](#).

Once the license key has been received and the information verified, you can proceed with the installation at step 2.

## **Step 2. Remove the Outer Cover**

For instructions, click the Chapter 7 bookmark “Removing the Covers” in the PDF Service Guide<sup>1</sup>.

## **Step 3. Remove the Front Panel Assembly**

For instructions, click the Chapter 7 bookmark “Removing and Replacing the Front Panel Assembly” in the PDF Service Guide<sup>1</sup>.

---

1. See [“Downloading the Online PNA Service Guide” on page 5](#).

## Step 4. Remove Some Bottom-Side (Test Set) Cables

---

**CAUTION** Be careful not to damage the center pins of the semirigid cables. Some flexing of the cables may be necessary but do not over-bend them.

---

---

**NOTE** When removing a cable, also remove the plastic cable clamp, if present. It is normal for some of the cable clamp's adhesive to remain.

---

1. Place the analyzer bottom-side up on a flat surface.
2. Remove the following semi-rigid cable, but keep it for reinstallation later.  
To see an image showing the location of the cable, click the Chapter 6 bookmark "Bottom RF Cables, Standard 2-Port Configuration, Option 200" in the PDF Service Guide<sup>1</sup>.
  - W24 (N5247-20061) A63 port 2 70 GHz doubler to W23
3. Remove and discard the following semi-rigid cables:
  - W30 (N5227-20045) A63 port 2 70 GHz doubler to A32 port 2 reference coupler
  - W12 (N5227-20041) A60 port 1 70 GHz doubler to W11
  - W27 (N5227-20044) A60 port 1 70 GHz doubler to A29 port 1 reference coupler
  - W134 (N5227-20005) A32 port 2 receiver coupler to A36 port 2 coupler
  - W131 (N5227-20004) A29 port 1 receiver coupler to A33 port 1 coupler
  - W135 (N5227-20007) A33 port 1 coupler to A27 mixer brick (A)
  - W127 (N5227-20003) A29 port 1 receiver coupler to A27 mixer brick (R1)  
**NOTE:** Remove and discard the 3 dB pad on A27 mixer brick (R1).
  - W130 (N5227-20006) A32 port 2 receiver coupler to A27 mixer brick (R2)
  - W138 (N5227-20008) A36 port 2 coupler to A27 mixer brick (B)
4. Leave the gray flexible cables, the wire harnesses, and the ribbon cables connected where possible. Any that are removed should be labeled for reconnection later.

---

1. Refer to "Downloading the Online PNA Service Guide" on page 5.

### Step 5. Remove Port 1 and Port 2 Coupler Assemblies from Brackets Underneath

Loosen the 3 screws on each coupler assembly and remove the assembly from the bracket underneath.

### Step 6. Remove Brackets From Test Set Deck

Remove the two brackets from the test set deck and discard. These are the brackets that had been connected to the Port 1 and Port 2 coupler assemblies.

### Step 7. Reinstall the Port 1 and Port 2 Coupler Assemblies to Test Set Deck

Refer to [Figure 1](#) for this step of the procedure. Use a T-10 TORX driver to tighten all screws.

**Figure 1** Port 1 and Port 2 Coupler Assemblies Reinstallation

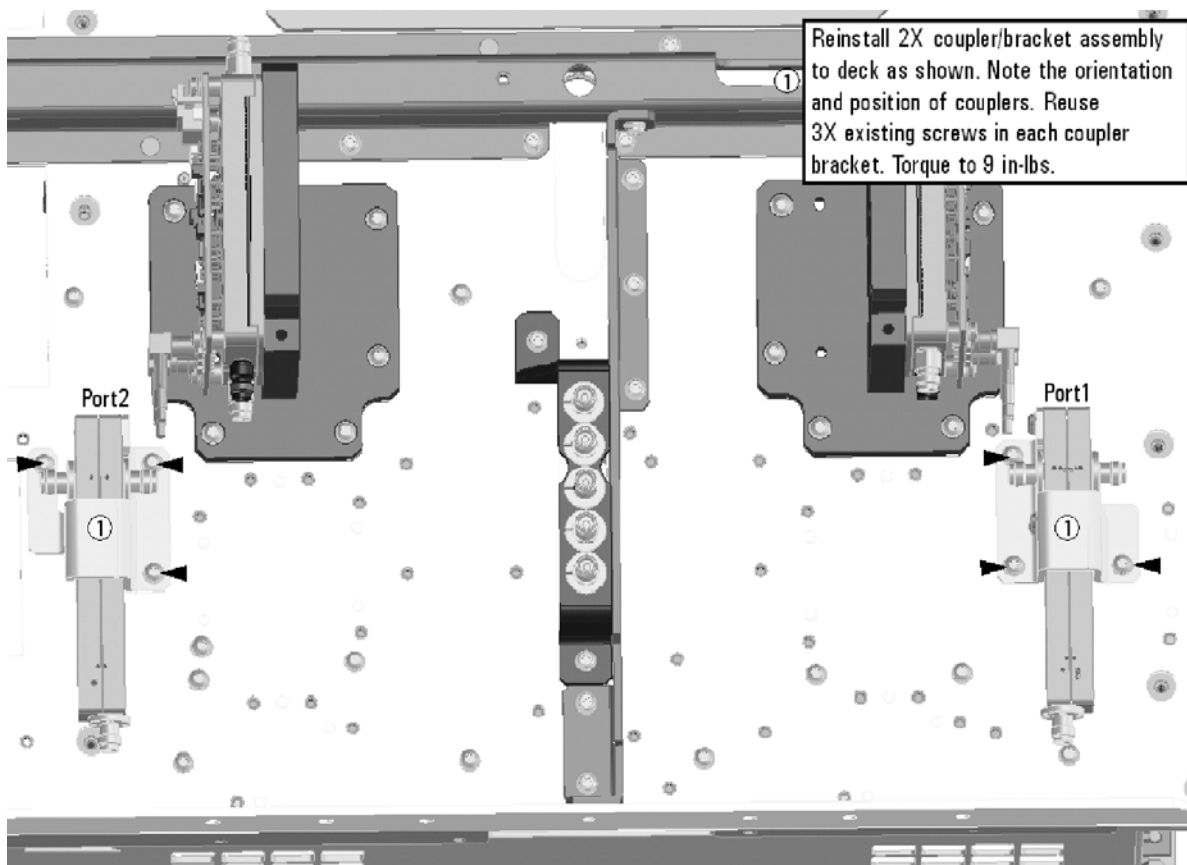

N5227\_101\_01

### Step 8. Assemble the Reference Mixer Switch

Install bracket N5245-00024 to the reference mixer switch 5087-7759 using two screws 0515-0372. Torque screws to 9 in-lbs.

## Step 9. Install the Reference Mixer Switch

Refer to [Figure 2](#) for this step of the procedure. Use a T-10 TORX driver to tighten all screws.

**Figure 2** Reference Mixer Switch Installation

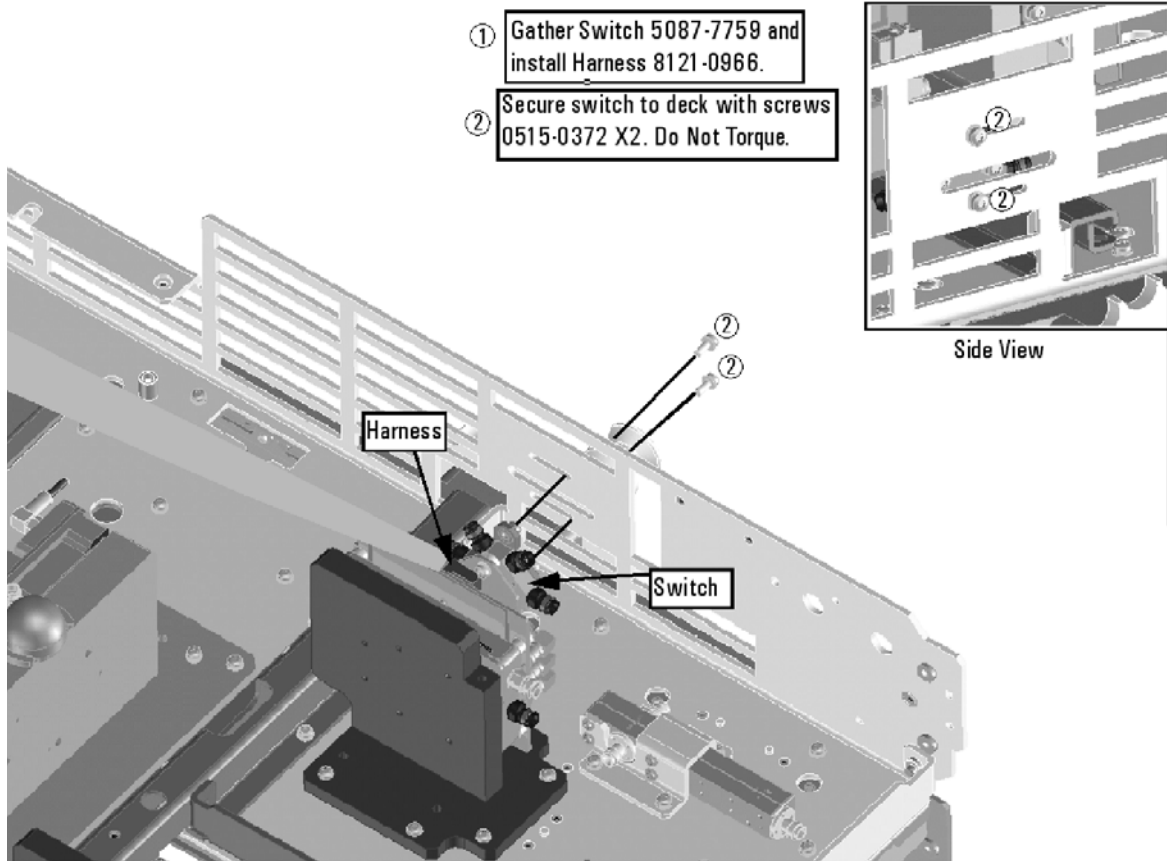

N5227\_101\_02

## Step 10. Remove the Test Set Front Plate Assembly From the Test Set Deck

Refer to [Figure 4 on page 15](#) to see the screws that must be removed. Keep the screws for reuse later.

## Step 11. Move the LED Boards and Couplers to the New Test Set Front Plate

Move the LED boards, test port couplers and their mounting nuts to the new test set front plate (part number N5247-00008).

Refer to [Figure 3](#) for this step of the procedure. New parts are listed in [Table 1 on page 7](#).

**Figure 3 Test Set Front Plate Assembly**

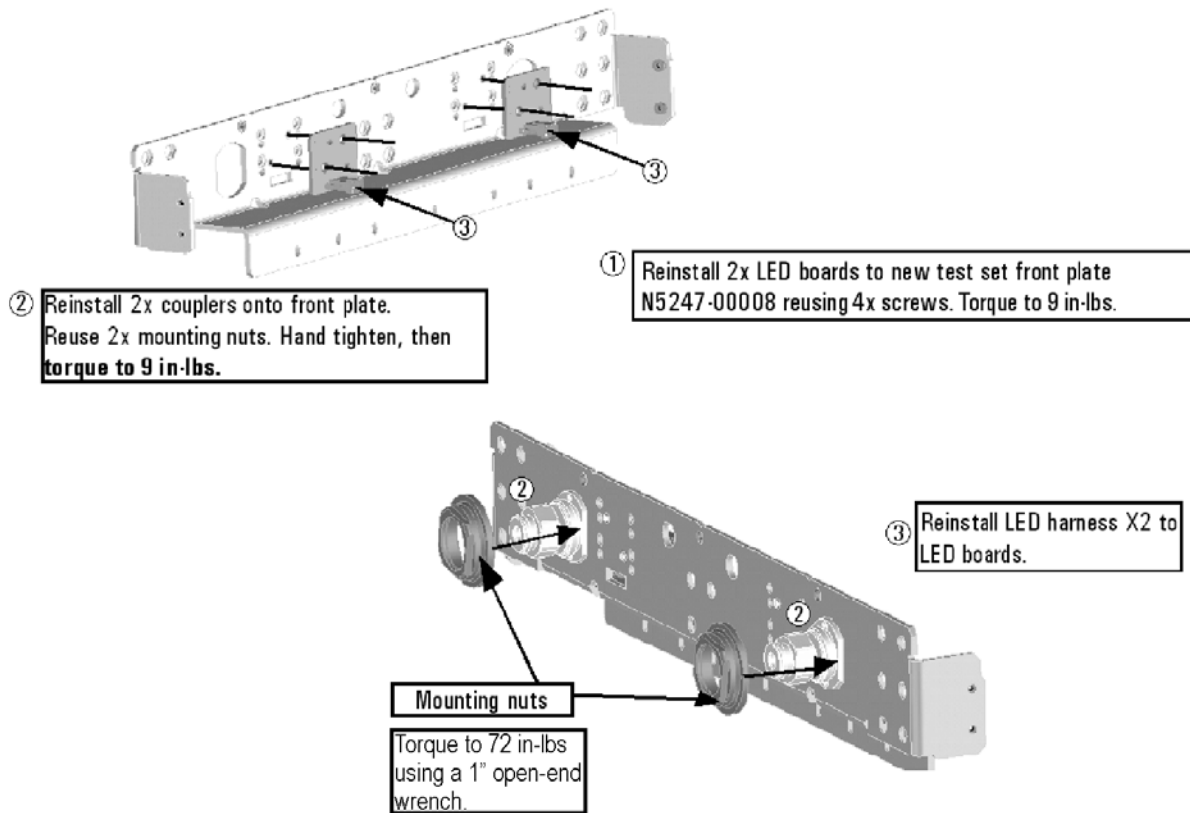

N5227\_101\_03

## Step 12. Install Bulkhead Connectors on the Test Set Front Plate Assembly

Install twelve bulkhead connectors to the test set front plate along with washers and nuts (hardware equipped with connector). Torque all nuts to 21 in-lbs. Refer to [Figure 4 on page 15](#) to see the location of the bulkhead connectors. New parts are listed in [Table 1 on page 7](#).



### Step 13. Install New Test Set Front Plate Assembly to Test Set Deck

Refer to [Figure 4](#) for this step of the procedure. New parts are listed in [Table 1](#) on [page 7](#).

**Figure 4** Test Set Front Plate Assembly Installation

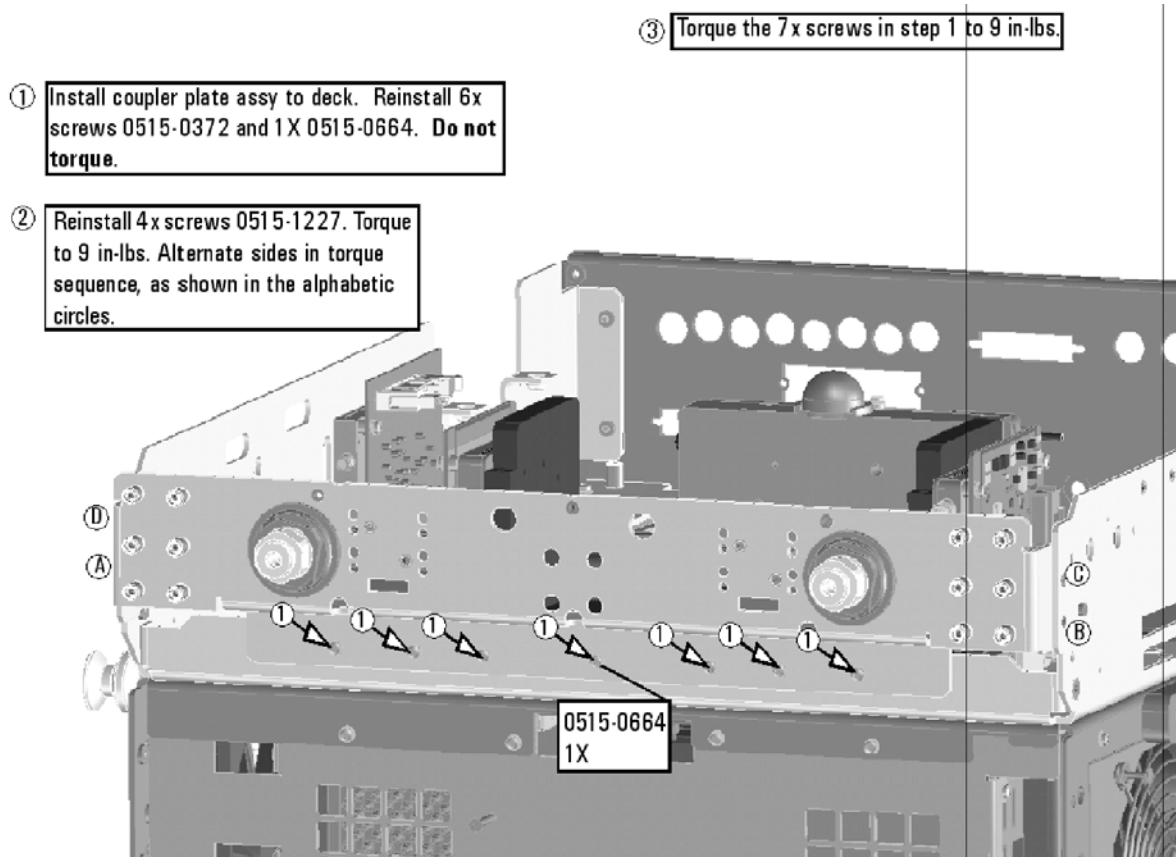

N5227\_101\_04

## Step 14. Install Some Bottom-Side (Test Set) Cables

**CAUTION** Use a 5/16-in torque wrench set to 10 in-lbs on all cable connections except the front and rear panel bulkhead connectors. Torque these connections to 21 in-lb.

**CAUTION** Be careful not to damage the center pins of the semirigid cables. Some flexing of the cables may be necessary but do not over-bend them.

### Semirigid Cables Required for Upgrading to an Option 201 PNA

To see images showing the location of these cables, click the Chapter 6 bookmark “Bottom RF Cables, 2-Port, Option 201” in the PDF Service Guide<sup>1</sup>. New parts are listed in [Table 1 on page 7](#).

- W45 (N5247-20057) A32 port 2 receiver coupler to front-panel REF 2 SOURCE OUT

\* As shown in [Figure 5](#), install clamp (part number 1400-1334) to secure cable W45.

**Figure 5** Location of Cable Clamps to Secure W45

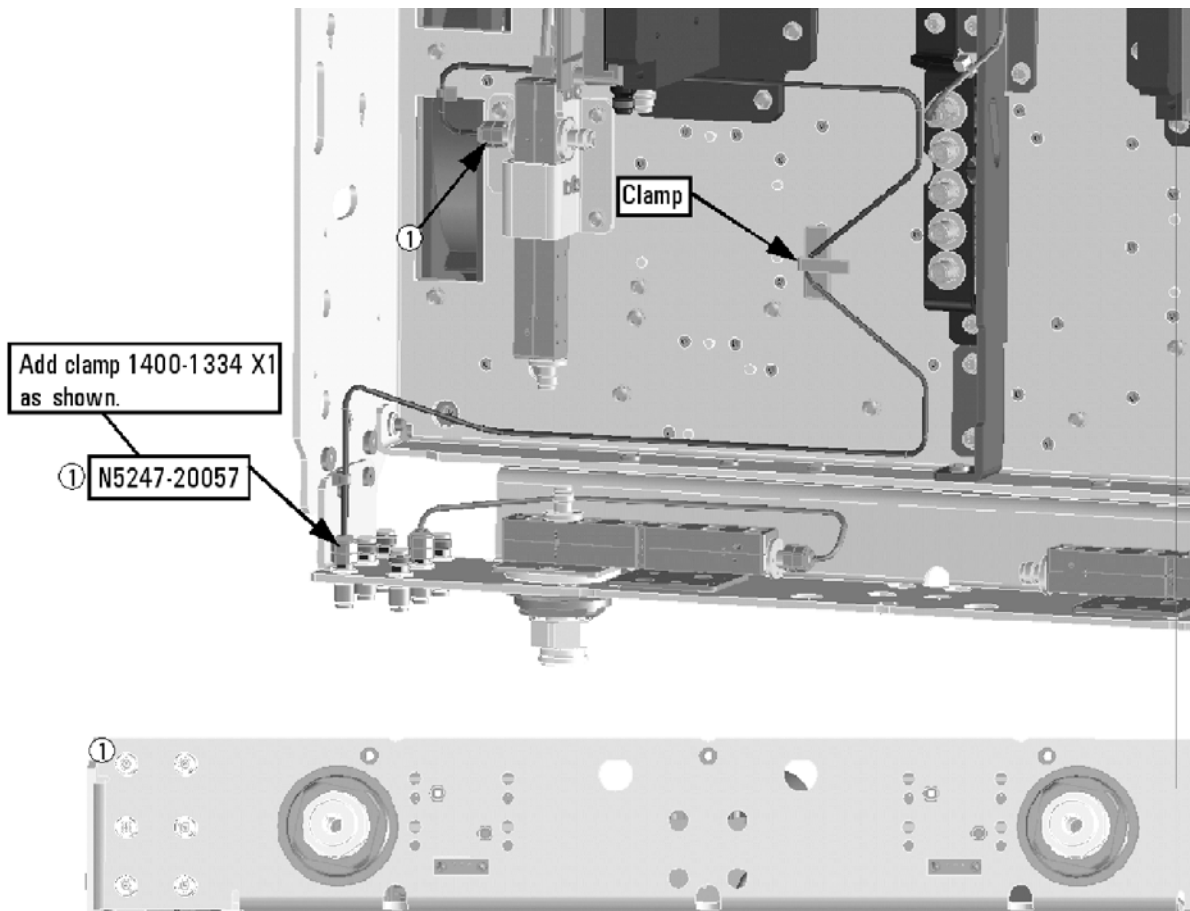

N5227\_101\_06

1. See “[Downloading the Online PNA Service Guide](#)” on page 5.

- W44 (N5247-20050) Port 2 CPLR THRU to A36 port 2 coupler
- W50 (N5247-20054) Front-panel port 2 RCVR B IN to A27 mixer brick (B)
- W46 (N5247-20041) A36 port 2 coupler to front-panel port 2 CPLR ARM
- W43 (N5247-20036) A32 port 2 receiver coupler to front-panel port 2 SOURCE OUT
- W56 (N5247-20055) REF 2 RCVR R2 IN to A27 mixer brick (R2)
- W24 (reuse) (N5247-20061) A63 port 2 70 GHz doubler to W23
- W30 (N5247-20052) A63 port 2 70 GHz doubler to A32 port 2 receiver coupler
- W51 (N5247-20011) Front-panel REF 1 SOURCE OUT to A37 ref mixer switch
- W33 (N5247-20056) A29 port 1 receiver coupler to A37 reference mixer switch

\* As shown in **Figure 6**, install clamp (part number 1400-1334) to secure cable W33.

**Figure 6** Location of Cable Clamps to Secure W33

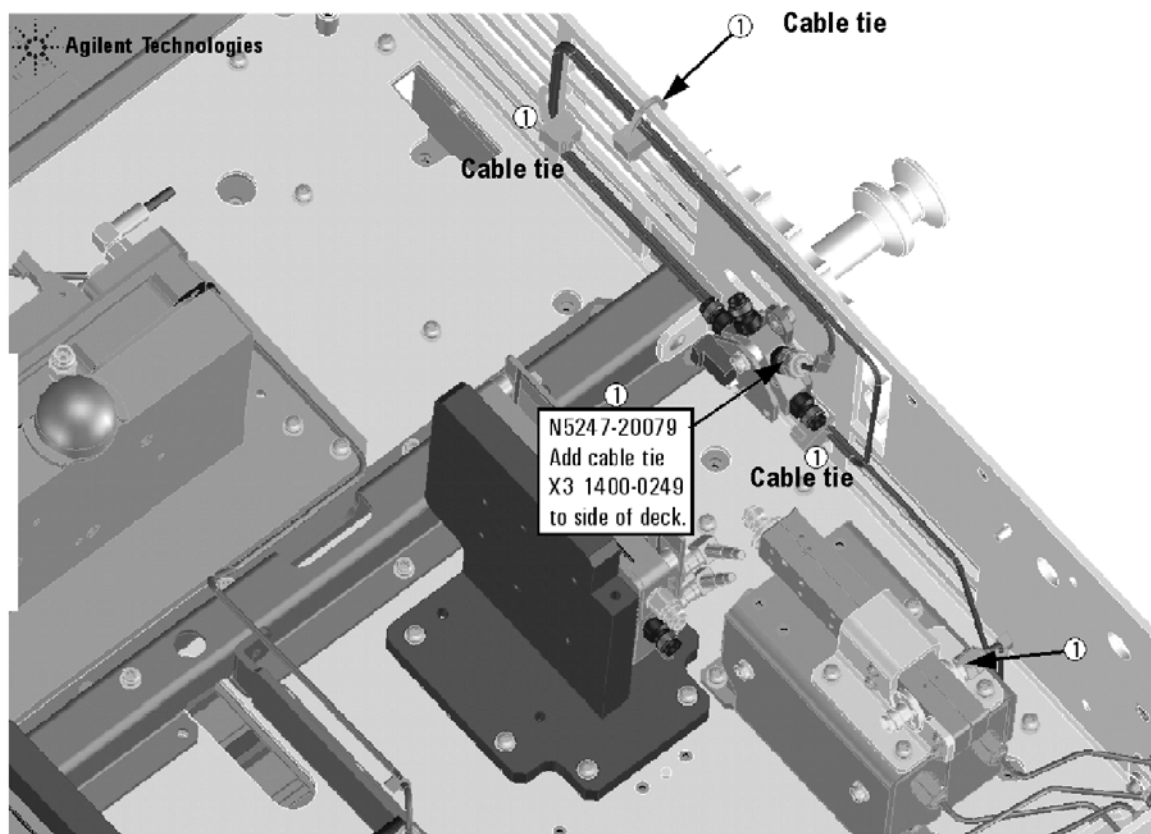

N5247\_101\_07

- W52 (N5247-20012) REF 1 RCVR R1 IN to A37 reference mixer switch

---

**NOTE** Torque the two screws securing the reference mixer switch to 9 in-lbs

---

- W47 (N5247-20053) Port 1 RCVR A IN to A27 mixer brick (A)
- W34 (N5247-20039) A33 port 1 coupler to front panel port 1 CPLR ARM
- W31 (N5247-20037) A29 port 1 receiver coupler to front-panel port 1 SOURCE OUT
- W32 (N5247-20049) Port 1 CPLR THRU to A33 port 1 coupler
- W27 (N5247-20074) A60 port 1 70 GHz doubler to A29 port 1 receiver coupler
- W12 (N5247-20059) A60 port 1 70 GHz doubler to W11
- W53 (N5247-20048) A37 reference mixer switch to A27 mixer brick (R1)

### **Install the Wire Harnesses**

To see an image showing the location of these wire harnesses, click the Chapter 6 bookmarks “Bottom Ribbon Cables and Wire Harnesses, 2-Port, Option 201” in the PDF Service Guide<sup>1</sup>. New parts are listed in [Table 1 on page 7](#).

If not already done, connect these wire harnesses:

- 8121-0966 A23 test set motherboard J554 to A37 reference mixer switch
- N5247-60016 (reuse) A19 test set motherboard J221 to port 1 LED board J1
- N5247-60016 (reuse) A19 test set motherboard J222 to port 2 LED board J1

---

1. See [“Downloading the Online PNA Service Guide” on page 5](#).

## Step 15. Remove the Old Lower Front Panel Overlay

Refer to [Figure 7](#) for this step of the procedure. Although a 4-port PNA is shown in the graphic, the concept is the same for the 2-port PNA. New parts are listed in [Table 1 on page 7](#).

1. From the back side of the front panel, use a blunt object in the cutouts in the lower front dress panel to push on the old overlay (item ①) and separate it from the front dress panel.
2. From the front side of the front panel, pull off the overlay completely and discard it.
3. Remove any adhesive remaining on the front panel.

**Figure 7** Lower Front Panel Overlay Replacement

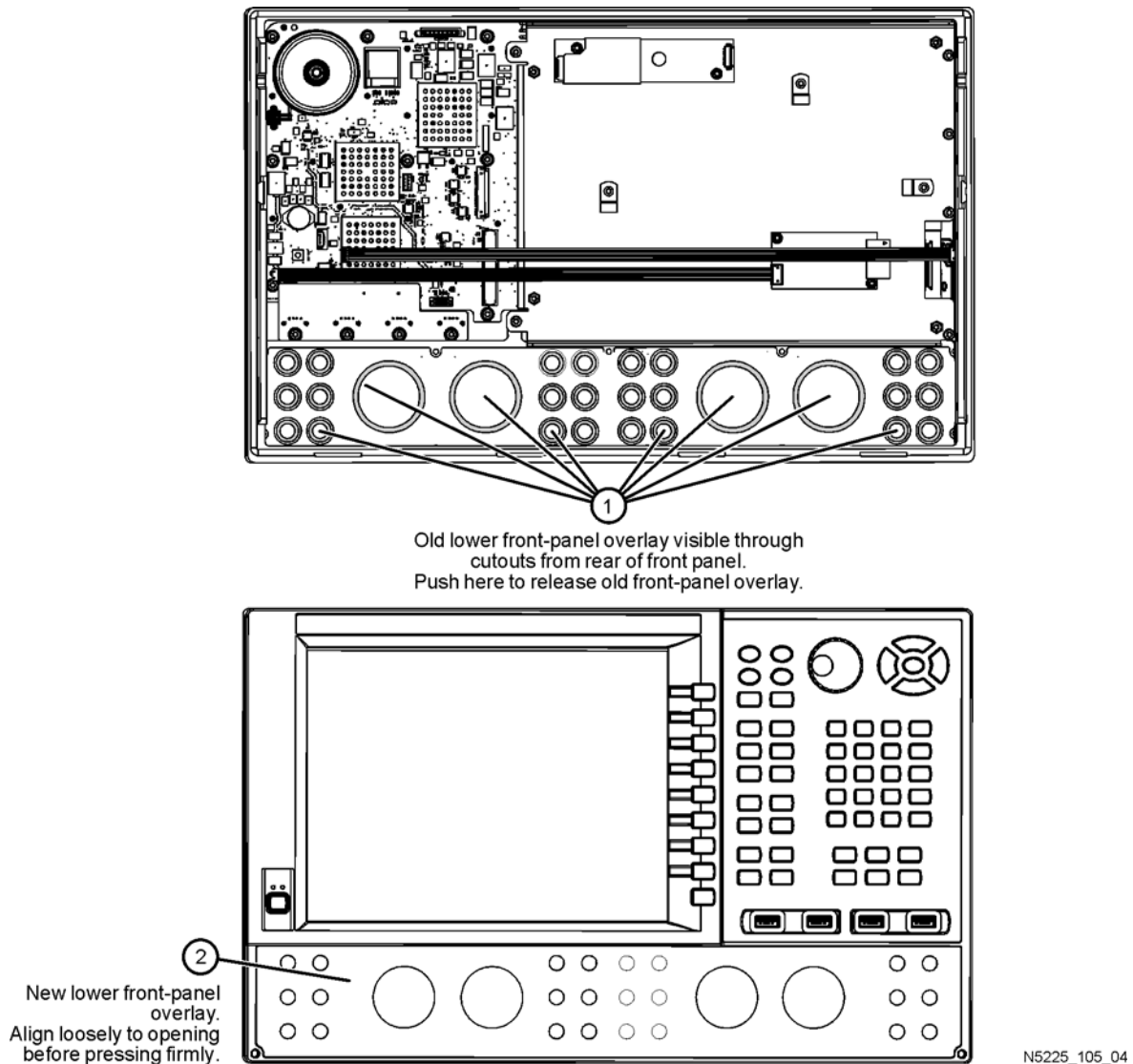

N5225\_105\_04

## Step 16. Reinstall Front Panel Assembly

Refer to [Figure 8](#) for this step of the procedure.

**Figure 8** Front Panel Assembly Installation

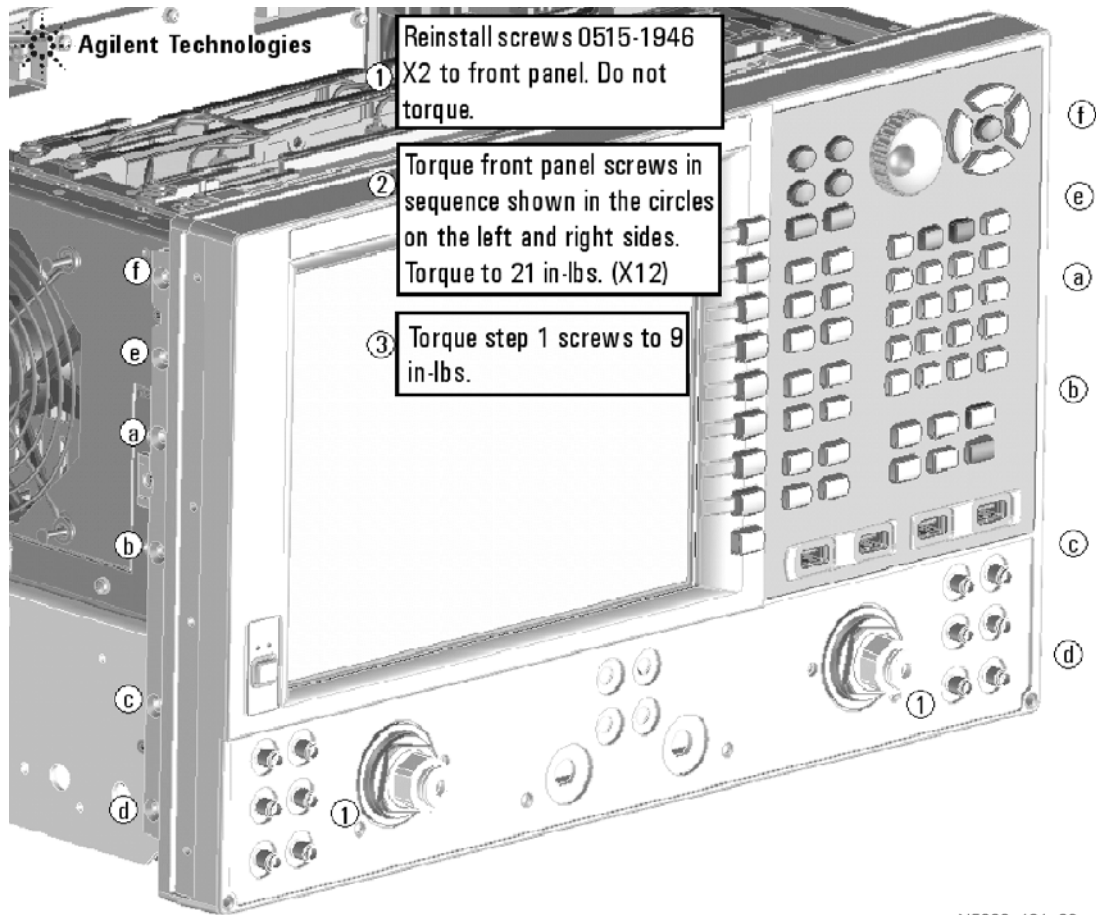

## Step 17. Install the New Lower Front Panel Overlay

Refer to [Figure 7 on page 19](#) for this step of the procedure. Although a 4-port PNA is shown in the graphic, the concept is the same for the 2-port PNA. New parts are listed in [Table 1 on page 7](#).

1. Remove the protective backing from the new front panel overlay, N5227-80015 (item ②).
2. Starting from either side, *loosely* place the overlay in the recess on the lower front panel, ensuring that it fits tightly against the edges of the recess.
3. Once the overlay is in place, press it firmly onto the frame to secure it.

## Step 18. Install Front Panel Jumpers

As shown in [Figure 9](#), install 6 front panel jumper cables (part number N5247-20107).

**Figure 9** Front Panel Jumper Cables Installation

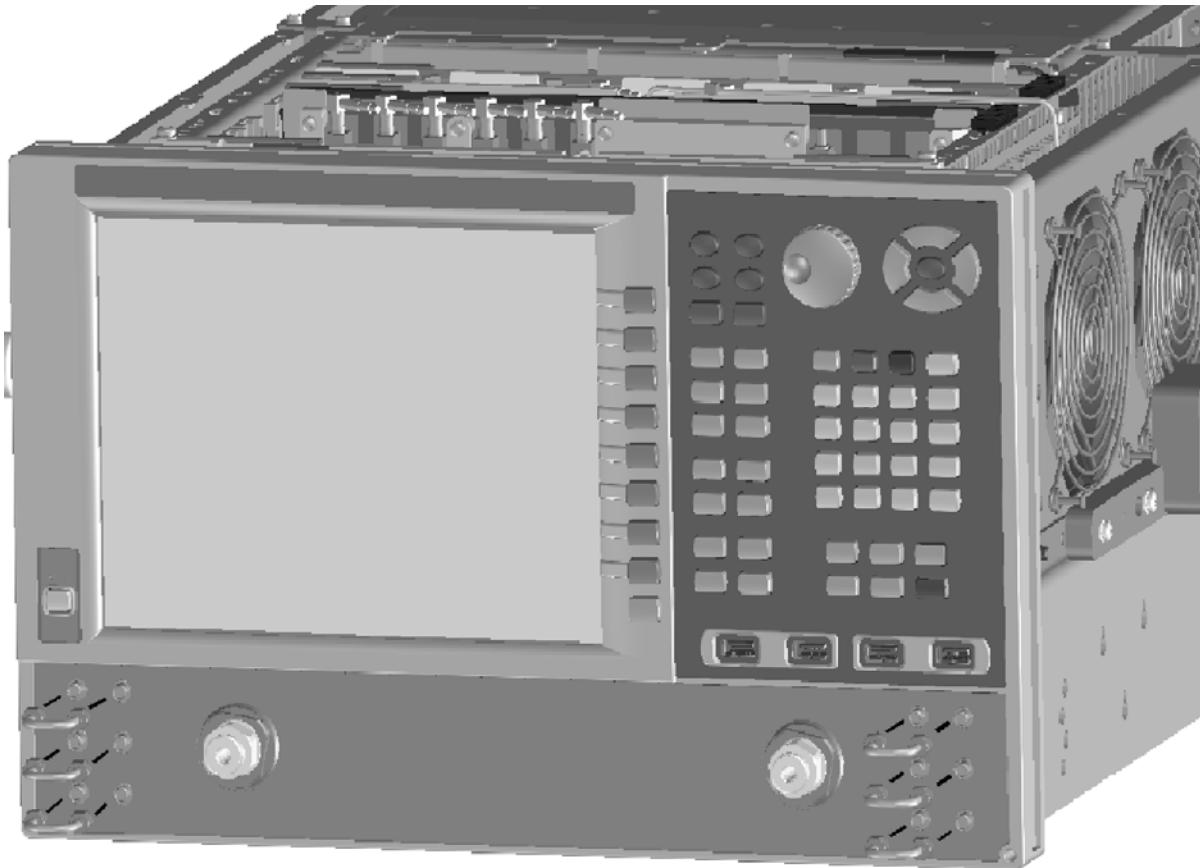

① Install 6x jumper cables N5247-20107 and torque to 10" lbs

N5227\_101\_05

## Step 19. Position the Cables and Wires to Prevent Pinching

On the top side of the PNA, carefully position the grey flex cables so they can't be pinched between the covers and the rails.

On the bottom side of the PNA, carefully fold or push down the ribbon cables and wires so they can't be pinched between the hardware and the outer cover. Ribbon cables and wires must never be positioned on top of hardware.

## Step 20. Reinstall the Outer Cover

For instructions, click the Chapter 7 bookmark “Removing the Covers” in the PDF Service Guide<sup>1</sup>.

## Step 21. Enable Option 201

### Procedure Requirements

- The analyzer must be powered up and operating to perform this procedure.
- The Network Analyzer program must be running.
- A keyboard must be connected to the network analyzer.

### Option Enable Procedure

1. To start the option enable utility, press UTILITY **System**, then **Service**, then **Option Enable**. An option enable dialog box will appear.
2. Click the arrow in the **Select Desired Option** box. A list of available options will appear.
3. In the **Select Desired Option** list, click **201 - Src/Rcvr Atten & Bias Ts 2-Port**.
4. Using the keyboard, enter the license key in the box provided. The license key is printed on the the license message you received from Keysight. Enter this key *exactly* as it is printed on the message.
5. Click **Enable**.
6. Click **Yes** in answer to the displayed question in the **Restart Analyzer?** box.
7. When the installation is complete, click **Exit**.

### Option Verification Procedure

Once the analyzer has restarted and the Network Analyzer program is again running:

1. On the analyzer’s **Help** menu, click **About Network Analyzer**.
2. Verify that “201” is listed after “Options:” in the display. Click **OK**.

---

**NOTE** If Option 201 has not been enabled, perform the “Option Enable Procedure” (above) again. If the option is still not enabled, contact Keysight Technologies. Refer to [“Getting Assistance from Keysight” on page 3](#).

---



## Step 22. Perform Post-Upgrade Adjustments and Calibration

### Adjustments

The following adjustments must be made due to the hardware changes of the analyzer.

- source adjustment
- receiver adjustment

These adjustments are described in the PNA Service Guide and in the PNA on-line HELP. A list of equipment required to perform these adjustments is also found in the service guide.

To view this Service Guide information, click the Chapter 3 bookmark “Tests and Adjustments” in the PDF Service Guide<sup>1</sup>.

After the specified adjustments have been performed, the analyzer should operate and phase lock over its entire frequency range.

### Operator’s Check

Perform the Operator’s Check to check the basic functionality of the analyzer. For instructions, click the Chapter 3 bookmark “Tests and Adjustments” in the PDF Service Guide<sup>1</sup>.

If you experience difficulty with the basic functioning of the analyzer, contact Keysight. Refer to [“Contacting Keysight” on page 3](#).

### Calibration

Although the analyzer functions, its performance relative to its specifications has not been verified. It is recommended that a full instrument calibration be performed using the analyzer’s internal performance test software. To view information on the performance test software, click the Chapter 3 bookmark “Tests and Adjustments” in the PDF Service Guide<sup>1</sup>.

## Step 23. Prepare the PNA for the User

1. If necessary, reinstall front jumper cables.
2. Install the cable guards, pushing them over the front jumper cables until the cushioning material touches the front panel of the PNA.
3. Install the dust caps on the test ports.
4. Clean the analyzer, as needed, using a damp cloth.

---

1. See [“Downloading the Online PNA Service Guide” on page 5](#).



This information is subject to change without notice.

© Keysight Technologies 2011–2015

April 2015



N5227-90101  
[www.keysight.com](http://www.keysight.com)